

2008/05/02 02:25:39 CAROL TRIBBLE

DRAWING FOR REFERENCE: This is subject to change without notice

COUNT	DESCRIPTION OF REVISIONS	BY	CHKD	DATE	COUNT	DESCRIPTION OF REVISIONS	BY	CHKD	DATE	
△					△					
△					△					
APPLICABLE STANDARD		EIAJ RC-5240								
RATING	OPERATING TEMPERATURE RANGE	-40 °C TO +85 °C			STORAGE TEMPERATURE RANGE	-40 °C TO +85 °C				
	VOLTAGE	AC 50V			OPERATING HUMIDITY RANGE	5 % TO 85 %				
	CURRENT	0.3 A			APPLICABLE CABLE	-				
SPECIFICATIONS										
ITEM		TEST METHOD			REQUIREMENTS				QT	AT
CONSTRUCTION										
GENERAL EXAMINATION		VISUALLY AND BY MEASURING INSTRUMENT.			ACCORDING TO DRAWING.				○	○
MARKING		CONFIRMED VISUALLY.							○	○
ELECTRIC CHARACTERISTICS										
CONTACT RESISTANCE		100 mA (DC OR 1000 Hz).			50 mΩ MAX.				○	-
INSULATION RESISTANCE		250 V DC.			100 MΩ MIN.				○	-
VOLTAGE PROOF		250 V AC FOR 1 min.			NO FLASHOVER OR BREAKDOWN.				○	○
MECHANICAL CHARACTERISTICS										
INSERTION AND WITHDRAWAL FORCES		MEASURED BY APPLICABLE CONNECTOR.			INSERTION FORCE 24.5 N MAX. WITHDRAWAL FORCE 2.5 N MIN.				○	-
MECHANICAL OPERATION		10000 TIMES INSERTIONS AND EXTRACTIONS.			① CONTACT RESISTANCE : 100 mΩ MAX. ② INSERTION FORCE 24.5 N MAX. WITHDRAWAL FORCE 1.9 N MIN. ③ NO DAMAGE, CRACK AND LOOSENESS, OF PARTS.				○	-
VIBRATION		FREQUENCY 10 TO 55 Hz, SINGLE AMPLITUDE 0.75 mm, AT 2 h, FOR 3 DIRECTIONS, TOTAL 6 h.			① NO ELECTRICAL DISCONTINUITY OF 1 μs. ② NO DAMAGE, CRACK AND LOOSENESS, OF PARTS.				○	-
SHOCK		490 m/s ² DIRECTIONS OF PULSE 11 ms AT 3 TIMES FOR 6 DIRECTIONS, TOTAL 18 TIMES.							○	-
ENVIRONMENTAL CHARACTERISTICS										
RAPID CHANGE OF TEMPERATURE		TEMPERATURE -40 → 25 → 85 → 25 °C TIME 30 → 2 TO 3 → 30 → 2 TO 3 min UNDER 5 CYCLES.			① CONTACT RESISTANCE : 100 mΩ MAX. ② NO DAMAGE, CRACK AND LOOSENESS, OF PARTS.				○	-
DAMP HEAT (STEADY STATE)		EXPOSED AT 40±2 °C, 90~95 %, 96 h (FOR 4 DAYS).			① CONTACT RESISTANCE : 100 mΩ MAX. ② INSULATION RESISTANCE : 10 MΩ MIN. ③ NO FLASHOVER OR BREAKDOWN. ④ NO DAMAGE, CRACK AND LOOSENESS, OF PARTS.				○	-
DRY HEAT		EXPOSED AT +85±2 °C, 96±4 h.			① CONTACT RESISTANCE : 100 mΩ MAX. ② NO DAMAGE, CRACK AND LOOSENESS, OF PARTS.				○	-
COLD		EXPOSED AT -40±3 °C, 96±4 h.			① CONTACT RESISTANCE : 100 mΩ MAX. ② NO DAMAGE, CRACK AND LOOSENESS, OF PARTS.				○	-
CORROSION SALT MIST		EXPOSED IN 5±1 % SALT WATER, 35±3 °C FOR 48 ±4 h.			① CONTACT RESISTANCE : 100 mΩ MAX. ② NO HEAVY CORROSION.				○	-
REMARKS					DRAWN	DESIGNED	CHECKED	APPROVED	RELEASED	
Unless otherwise specified, refer to JIS C 5402.					<i>M. Shimogawa</i> 04.2.27	<i>M. Shimogawa</i> 04.2.27	<i>H. Nakamura</i> 04.3.1	<i>[Signature]</i> 04.3.2		
					Note QT:Qualification Test AT:Assurance Test ○:Applicable Test					
HRS HIROSE ELECTRIC CO., LTD.					SPECIFICATION SHEET			PART NO. MQ212-10P		
CODE NO.(OLD) CL		DRAWING NO. ELC4-124599			CODE NO. CL206-2446-5			1/2		

TO
□
□
□

SPECIFICATIONS				
ITEM	TEST METHOD	REQUIREMENTS	QT	AT
SOLDERBILITY	SOLERRING POINT OF CONTACTS IMMERSION IN SOLDER BATH OF 350±5°C, 2±0.5 sec.	SOLDERING POINT OF CONTACTS IMMERSION IN SOLDER, 90% MIN.	<input type="radio"/>	—
RESISTANCE TO SOLDERING HEAT	MOLTEN-SDDER TEMPERATURE: 260±5°C. IMMERSION FURABILITY PER LOCATION: 2± 1 sec.	NO DAMAGE, CRACK AND LOOSENESS, OF PARTS.	<input type="radio"/>	—

REMARKS	DRAWN	DESIGNED	CHECKED	APPROVED	RELEASED
	<i>M. Shimogawa</i> 04.2.27	<i>M. Shimogawa</i> 04.2.27	<i>H. Ishikawa</i> 04.3.1	<i>[Signature]</i> 04.3.2	

Note QT:Qualification Test AT:Assurance Test ○:Applicable Test

HRS HIROSE ELECTRIC CO., LTD.	SPECIFICATION SHEET	PART NO. MQ212-10P
CODE NO.(OLD) CL	DRAWING NO. ELC4-124599	CODE NO. CL206-2446-5

2
2

1 2 3 4 5 6 7 8

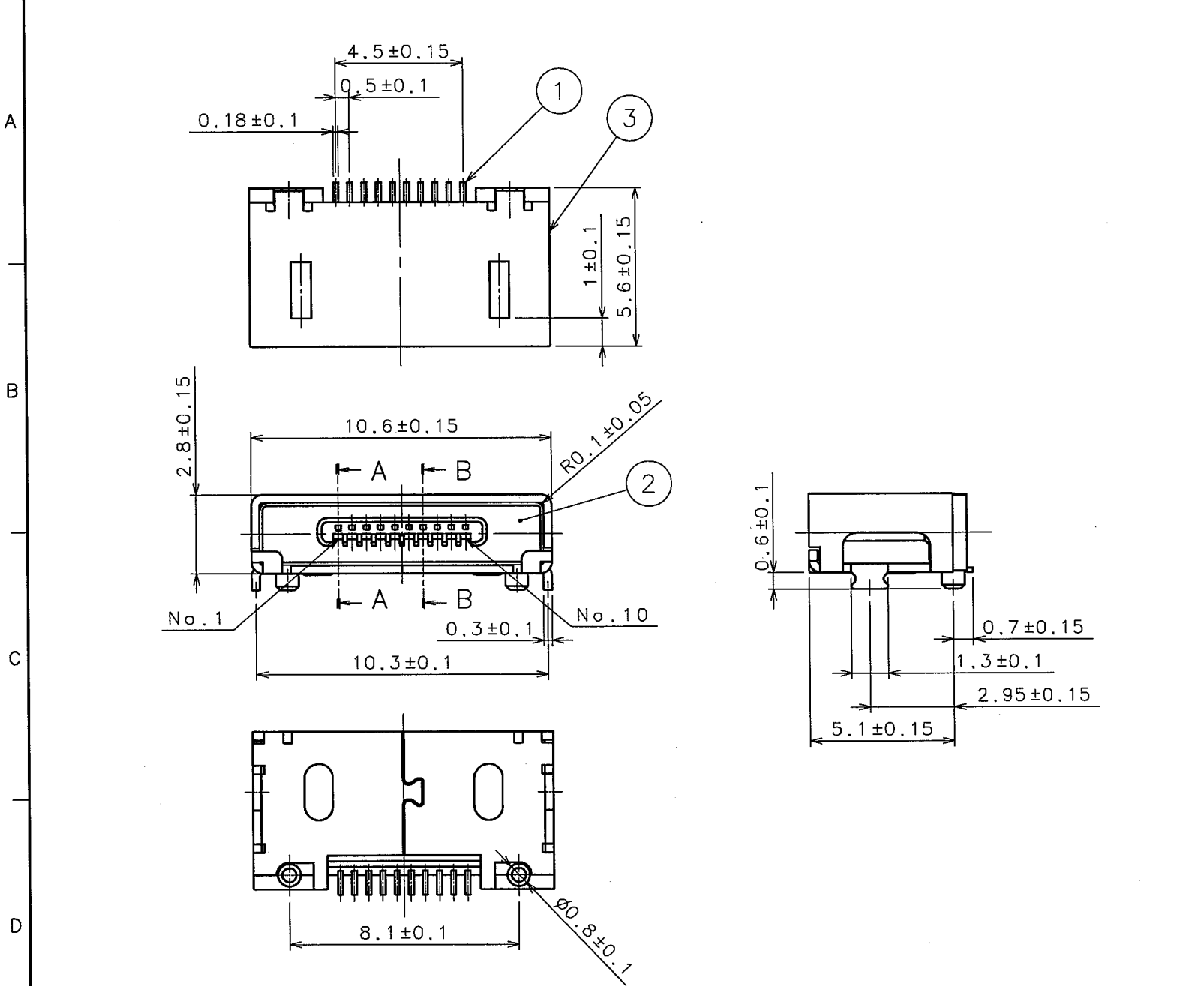

FIGURE FOR PACKING

UNEINDING DIRECTION

UNEINDING DIRECTION

COUNT	DESCRIPTION OF REVISIONS	BY	CHKD	DATE	COUNT	DESCRIPTION OF REVISIONS	BY	CHKD	DATE

RECOMMENDED PC BOARD PATTERN

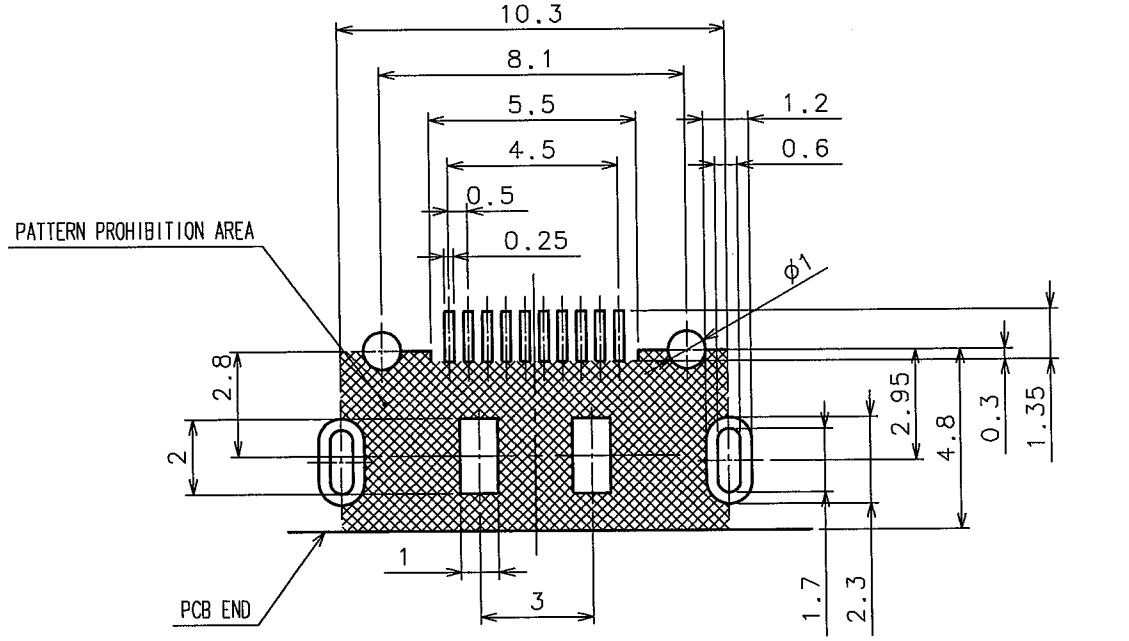

A-A (10:1)
(CONTACT No. 1, 10)

B-B (10:1)
(CONTACT No. 2~9)

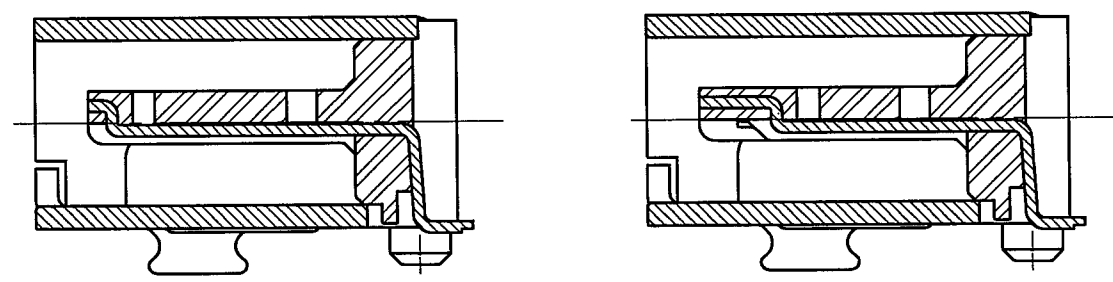

NOTE 1 PER REL: 1500 PIECES.
2 CO-PLANARITY TO BE 0.1mm MAX.

2	LCP	UL94V-0 (BLACK)	5	PS	
1	PHOSPHOR BRONZE	UNDER PLATING: NICKEL $2\mu\text{m}$ MIN CONTACT AREA: GOLD $0.2\mu\text{m}$ MIN LEAD AREA: GOLD FLASH	4	PS	
			3	PHOSPHOR BRONZE	UNDER PLATING: NICKEL $1\mu\text{m}$ MIN MOUNTING AREA: TIN $1\mu\text{m}$ MIN
NO.	MATERIAL	FINISH, REMARKS	NO.	MATERIAL	FINISH, REMARKS

CODE NO. (OLD)	DRAWN	DESIGNED	CHECKED	APPROVED	RELEASED
	<i>m. Shimoyama</i>	<i>m. Shimoyama</i>	<i>M. Nakamura</i>	<i>[Signature]</i>	
	04.2.27	04.2.27	04.3.1	04.3.2	

SCALE 5 : 1	DRAWING NO. EDC3-124599	PART NO. MQ212-10P
UNITS mm	HRS HIROSE ELECTRIC CO., LTD	CODE NO. CL206-2446-5

TO
Q